

Autonics

Door Side Sensor ADS-SE

M A N U A L



Thank you very much for selecting Autonics products.
For your safety, please read the following before using.

Caution for your safety

*Please keep these instructions and review them before using this unit.

*Please observe the cautions that follow:

Warning Serious injury may result if instructions are not followed.

Caution Product may be damaged, or injury may result if instructions are not followed.

*The following is an explanation of the symbols used in the operation manual.

Caution: Injury or danger may occur under special conditions.

Warning

1. Please use it with double safety devices when it is used at the equipments which may cause damages to human life or assets (Ex:Nuclear power control, Medical equipment, Vehicle, Train, Air plane, Combustion apparatus Entertainment or Safety device etc.)

It may cause a fire, human life or assets.

2. Do not connect wires in power ON.

It may cause an electric shock.

3. Do not disassemble and modify this unit, when it requires.

If needs, please contact us.

It may give an electric shock and cause a fire.

Caution

1. Use it with auto door sensor for safety.

It may cause damage of assets or human injury.

2. This unit shall not be used outdoors.

It might shorten the life cycle of the product or give an electric shock.

3. Do not use this unit in place where there is flammable or explosive gas.

It may cause a fire or explosion.

4. Please observe specification rating.

It may shorten the life cycle or damage to the product.

5. Do not do wrong wiring.

It may result in damage to this unit.

6. Do not use this unit in place where there is vibration.

It may result in damage to this unit.

7. In cleaning the unit, do not use water or an oil-based detergent.

It might cause an electric shock or fire that will result in damage to the product.

8. Do not use the load beyond rated switching capacity of Relay contact.

It may cause insulation failure, contact melt, contact failure, relay broken, fire etc.

Option

< Bracket >

• For mounting by one push

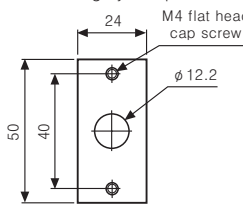

• For mounting by screw

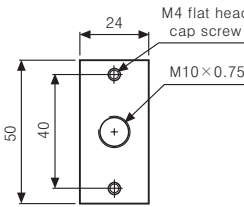

• ADS-SB12

* Amp(ADS-SEC), Sensor cable 10m(ADS-SH) : Option

Installation

Caution for sensor installation

- Detecting distance is 10m. Please install it in rated distance.
- Please install the sensor with more than 50cm gap from the bottom and ceiling. It may cause malfunction by reflected beams from the surface of the bottom and ceiling.
- Please don't put obstacles between emitter and receiver. It may cause malfunction.
- This product is for indoor. Please avoid the place where exposed in direct sunlight or is in over rated intensity of illumination.

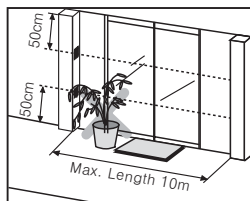

1. Please make a hole on the side post of auto door as follows.

- When not using the mounting bracket
 - Mounting hole of sensor head: $\phi 12.2\text{mm}$
- When using the mounting bracket
 - Through hole of sensor head : $\phi 13$ to $\phi 14\text{mm}$
 - Screw hole for fixing the bracket : M4 TAP or $\phi 3.5$

Caution For mounting hole

- Please check the mounting holes for the head of emitter and receiver are in parallel for the optical axes.
- Please grind around the mounting holes drilled smoothly. It may heat by the sharp part and cause malfunction by sensor head inclined.

2. Please mount the sensor head in the mounting hole

- When not using the mounting bracket
 - One push method
 - Please insert the sensor head into the mounting hole like the right picture.
- When using the mounting bracket
 - One push method
 - Please install the sensor head at the bracket first.
 - Please fix the bracket by screws on the place for installing.

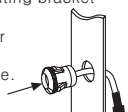

Caution When installing in One push method

- Please check the nuts are fixed on the sensor body tightly.
- Please install that there is no gap between the nuts and the side of the door (or bracket). It may cause malfunction because sensitivity setting is not available as the optical axes are not matched if sensor body is inclined.

Caution After installing the sensor head

- Please check the damage such as scratches or pollutant on the lens of the sensor head. It may cause malfunction in the condition of a beam cut off or lack of sensitivity by dust.

Caution For maintenance and mending

- Please keep the sensor head clean. It may not operate normally. Please clean it by a piece of cloth with a neutral detergent. But, do not use organic solvent. It may cause damage to lens of the head by organic solvent.
- Do not rinse the head part of the sensor. It may cause damage by water.

- When using the mounting bracket
 - One push method
 - Please install the sensor head at the bracket first.
 - Please fix the bracket by screws on the place for installing.

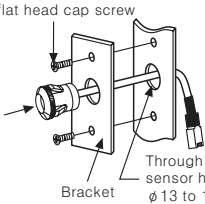

- Screw method
 - Please remove nuts and the head holder from the sensor head.
 - Please install the sensor head on the bracket.
 - Please fix the bracket on the side post of the door by screws.

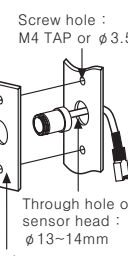

*The mounting bracket is optional. If necessary, please purchase it.

Specifications

Model	ADS-SE
Sensor wire length	10m
Detecting type	Through-beam type
Detecting distance	0 to 10m
Power supply	12V-24VAC/DC $\pm 10\%$ (Ripple P-P: Max. 10%)
Power consumption/Current	AC : Max. 2VA / DC : Max. 50mA
Contact output	Contact capacity : 50VDC 0.3A (Resistive load) Contact composition : 1C Relay life cycle : Mechanical—Min. 5,000,000 times, Electrical—Min. 100,000 times
Response time	Approx. 50ms (From a beam cut off)
Output holding time	Approx. 500ms (From a beam received)
Available sensor set	2set
Indication	Operating indicator (See "How to use" for the display status in operation)
Light source	Infrared diode (850nm modulated)
Environment	Ambient temperature -20 to +55°C (at non-freezing condition) Storage temperature -25 to +60°C Ambient humidity 35 to 85%RH Storage humidity 35 to 85%RH Ambient illumination Sunlight : Max. 100,000lx (Illumination of received light side)
Protection	IP40 (IEC specification)
Material	Case : ABS, Lens : PMMA
Accessories	Sensor 1set, Fixed bolt 2piece
Weight	Approx. 300g

Dimensions

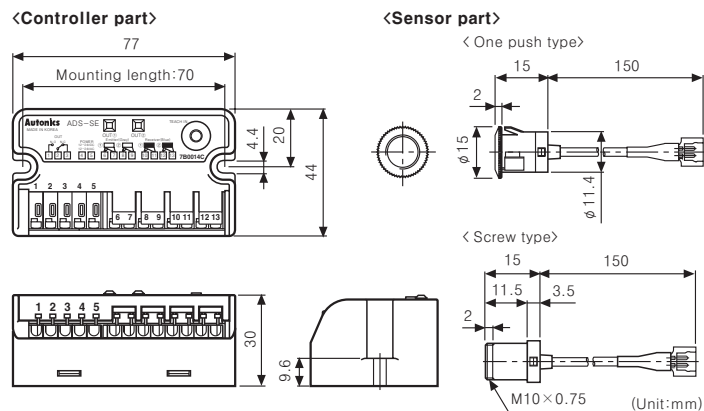

Identification

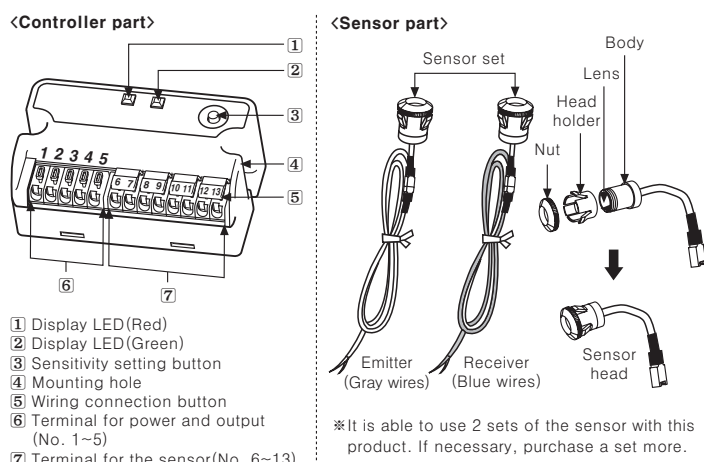

Controller installation

- Please fix controller with the bolts (M4 x 20, 2pcs). Please process the fixing hole of controller by M4. Please see dimension for installation.

Warning When fixing controller

- Please do not screw the bolts too tightly. The fixing hole of controller may be broken.

Wiring connection

1. Please follow as below when adjusting wiring length.

- Please cut off the wiring length as much as user needs.
- Please connect the wire to the terminal after taking off the wire covering. It will be easy to connect if soldering the end of the wires.

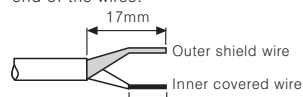

2. Please match wires in the number of terminals and connect them.

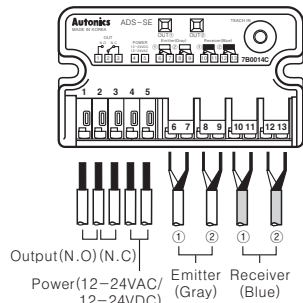

- Connection method for sensor
 - Please put outer shield and inner covered wires at once, pressing the inserting button, then take off from the button.

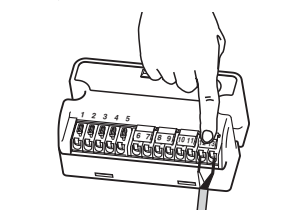

- Connection method for power and output wires
 - Please put the wires pressing the terminal by a driver etc..

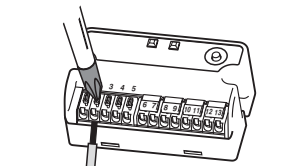

- Allowable diameter of power and output wires
 - Single wire: $\phi 0.12$ to 1.6mm (AWG26-16)
 - Stranded wire: $\phi 0.13$ to 1.5mm^2 (AWG26-16)

How to use

Sensitivity setting

Please set sensitivity after installing this product for a normal operation. Sensitivity setting is what set the optimum sensitivity automatically at the controller according to installed environment.

Order	LED display	Status
Press sensitivity setting button	Red/Green Flickering by turns	Ready
After more than 1sec.	All LED OFF	The beginning of sensitivity setting
Take off from button	Flickering at once	The end of sensitivity setting
	Displaying operation status	

Caution Before sensitivity setting

- Please check the wiring again with the connection diagram.
- When setting sensitivity, the through beam must not be shaken and cut off.
- Please don't put obstacles like a pot on the passage of the through beam.
- It may cause malfunction in above cases from lack of sensitivity or abnormal sensitivity setting.

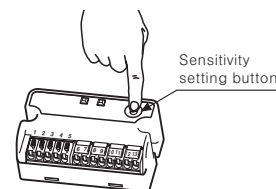

Please check LED display after setting the sensitivity.

- When the pressing time of sensitivity setting button is shorter than 1sec, sensitivity setting is cancelled, then it operates by previous setting.

Sensitivity status and check after setting sensitivity

Connecting sensor	LED display		Status	
	Red	Green	After setting sensitivity	In operation
1set	LED ON ■ Flickering □	LED OFF □	Sensitivity setting success	Beam received
	LED OFF □ Flickering □	LED ON ■	Sensitivity setting failure	Emitter disconnected or added
	Flickering □ Flickering □	LED ON ■	---	Lack of sensitivity
2set	LED ON ■ LED ON ■	LED ON ■	1, 2Channel sensitivity setting success	1, 2Channel beam received
	LED ON ■ LED OFF □	LED OFF □	1Channel success, 2Channel failure	Lack of 2channel sensitivity
	LED ON ■ Flickering □	LED ON ■	---	1Channel beam received, 2Channel beam cut off
	LED OFF □ LED ON ■	LED OFF □	1Channel failure, 2Channel success	1Channel beam cut off, 2Channel beam received
	Flickering □ LED ON ■	LED ON ■	---	1 Lack of channel sensitivity
	LED OFF □ LED OFF □	LED OFF □	1, 2Channel sensitivity setting failure	Lack of channel sensitivity or emitter disconnected
Flickering □ Flickering □	Flickering □	---	1, 2Channel beam cut off	

*After completing sensitivity setting in using an through beam red LED is flickering, green LED is off. Only red LED displays the operation status.

*After completing sensitivity setting in using two through beams red LED indicates the operation status of receiver set by receiver ① and green LED indicates the operation status of receiver set by receiver ②.

*Self diagnostic function
If lack of sensitivity occurs by optical axes not matched and pollution by dust on the lens of Emitter/Receiver etc. in operation the LED of normal operation channel will be cut off due to unstable operation.

Check process for sensitivity setting failure

- Please check obstacles between the heads of Emitter/Receiver.
 - Please check pollutant on the lens of Emitter/Receiver.
 - Please check wires cut off and the connection with the connection diagram on the controller.
 - Please check if the head of Emitter/Receiver is inclined or not.
 - Please set sensitivity again after removing above problem.
- *When sensitivity setting is failure even though above problem is solved please contact us.

Operation check

Please check the operation flow chart below.

Operation			
LED display	LED OFF	LED ON (Red/Green)	LED OFF
Status	-Power OFF	-Normal operation -No human or any material between sensors	-Human or material is passing between sensors (When through beam cut off)
Relay output	N.O OPEN N.C CLOSE	OPEN CLOSE	CLOSE OPEN

Trouble shooting

Trouble	Check	Correction action
It is not work.	<ul style="list-style-type: none"> Power voltage Cable cut, disconnection Rated detecting distance 	<ul style="list-style-type: none"> Check the power cable and adjust power voltage. Please check wiring and terminal. Use it in rated detecting distance.
Sometimes it is not work.	<ul style="list-style-type: none"> Pollution by pollutant on the lens of Emitter/Receiver. 	<ul style="list-style-type: none"> Remove the pollutant.
It is operated even if people does not enter in detection area.	<ul style="list-style-type: none"> Rated detecting distance There are obstacles between Emitter and Receiver. There are equipments generating strong noise or ratio wave (Motor, Generator, High-tension wire). 	<ul style="list-style-type: none"> Use it in rated detecting distance. Remove obstacles. Keep away from the equipment generating strong noise or ratio wave.

Caution for using

- When using two sets of sensor closely it may cause mutual interference by the emitter of other sensor. Therefore, please install them to avoid the interference by exchanging the head of Emitter and Receiver and by keeping the distance between the heads in more than 50cm.
- When installing the sensor head on the ceiling or floor closely it may cause malfunction by receiving the reflected beam. Therefore, please install it by keeping the suitable height (more than 50cm) from the ceiling or floor.
- When the target is a translucent or small object ($\phi 15\text{mm}$ max.) it may not detect as the light transmits them.
- When pressing the wiring of sensor in the same pipe laying with the high-tension wire or power line it may cause malfunction. Therefore, please use separated wiring or pipe laying.
- What using it in much dusty or corroded place may cause malfunction. Please avoid these places when installing.
- When making the length of the wiring (power wire or output wire) long it may cause malfunction by surge etc.
- When the lens of sensor head is polluted by dust etc. please clean it by dried cloth slightly. Do not use organic solvent like thinner.
- When using switching power supply as the source of supplying power please ground F.G terminal and install a condenser for removing noise between 0V and F.G terminal as following drawing.

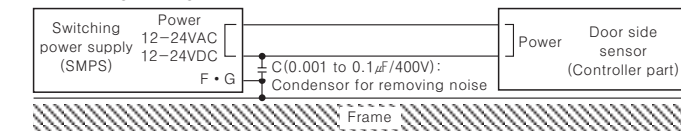

*It may cause malfunction if above instructions are not followed.

Main products

- COUNTER
- TIMER
- TEMPERATURE CONTROLLER
- PANEL METER
- TACHO/LINE SPEED/PULSE METER
- DISPLAY UNIT
- PROXIMITY SENSOR
- PHOTOELECTRIC SENSOR
- FIBER OPTIC SENSOR
- PRESSURE SENSOR
- ROTARY ENCODER
- SENSOR CONTROLLER
- POWER CONTROLLER
- STEPPING MOTOR & DRIVER & CONTROLLER
- LASER MARKING SYSTEM (CO₂, Nd:YAG)

Autonics Corporation
http://www.autonics.com

Satisfiable Partner For Factory Automation

HEADQUARTERS :
41-5, Yongdang-ro, Ulsang-eup, Yangsan-si, Gyeongsang, 626-847, Korea
INTERNATIONAL SALES :
Bldg. 402 3rd Fl., Bucheon Techno Park, 193, Yakdae-dong, Wonmi-gu, Bucheon-si, Gyeonggi-do, 420-734, Korea
TEL: 82-32-329-0722 / FAX: 82-32-329-0728
E-mail : sales@autonics.net

*The above specifications are changeable without notice anytime.

EP-KE-77-0003C